



8 3/4" ETA 2000-1

CT 2000-1 ESI 404537 09 25.10.2011

8 3/4" Ø 19,40 mm

Movement height	Altura sobre máquina	Altezza sopra movimento	3,60 mm
Running time	Reserva de marcha	Riserva di marcia	40 h
Number of jewels	Número de piedras	Numero di pietre	20
Angle lift of balance	Ángulo de alzamiento	Angolo de alzamento	50°
Frequency	Frecuencia	Frequenza	28'800 A/h

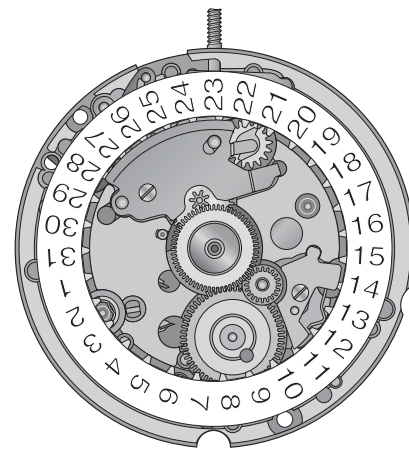
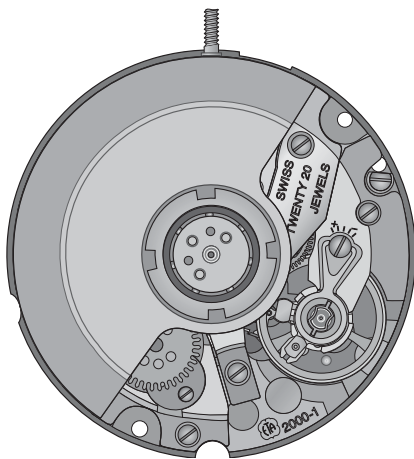

The repair and reconditioning work must only be performed by properly trained personnel.
Las tareas de reparación y revisión sólo deben ser llevadas a cabo por personal debidamente formado.
I lavori di riparazione e di revisione devono essere eseguiti esclusivamente da personale adeguatamente formato.



General information



Before starting work, please study this "Technical communication" carefully.



Eye protection is obligatory for all operations / work on the movement!



ETA SA disclaims any liability in case of damage arising from failure to observe this "Technical communication".

Environmental protection requirements



The legal provisions relating to waste handling and disposal must be observed in all operations / work on the movement!

In particular, lubricating and cleaning products harmful to the environment must be disposed of in accordance with the rules!



Substances prone to cause water pollution must be stored, transported, collected and disposed of in appropriate vessels.

Under no circumstances must they pollute the soil or be poured into sewage systems!

Explanation of symbols



Caution! Risk of material damage!

Below are some obligatory instructions for preventing any material damage!

Información general



Esta "Comunicación técnica" deberá estudiarse muy bien **antes** de comenzar los trabajos.



Es obligatorio utilizar protección ocular para todos los trabajos en y con el reloj.



ETA SA no se hace responsable de los daños provocados como consecuencia de la inobservancia de esta "Comunicación técnica".

Normas de protección medioambiental



Deberá cumplirse la normativa legal relativa al reciclaje y la eliminación correctos de los residuos en todos los trabajos en y con el reloj.

En especial, deberán eliminarse correctamente los productos lubricantes y de limpieza peligrosos para el medio ambiente.



Las sustancias contaminantes del agua deben recogerse, almacenarse, transportarse y eliminarse en recipientes adecuados.

En ningún caso se permitirá que contaminen el suelo o que lleguen a la canalización.

Significado de los símbolos



Atención Peligro de daños materiales

Instrucciones que deberán respetarse necesariamente para evitar daños materiales.

Informazioni generali



Questa "Comunicazione Tecnica" deve essere studiata attentamente **prima** dell'inizio dei lavori.



Per tutti i lavori su e con il movimento dell'orologio è obbligatorio proteggere gli occhi!



ETA SA declina qualunque responsabilità per eventuali danni causati dalla mancata osservanza della presente "Comunicazione tecnica".

Disposizioni relative alla protezione ambientale



Per tutti i lavori su e con il movimento dell'orologio si dovranno rispettare le disposizioni di legge relative al corretto riciclaggio e smaltimento dei rifiuti!

In particolare si dovrà provvedere al corretto smaltimento di lubrificanti e detergenti nocivi per l'ambiente!



Le sostanze inquinanti per l'acqua devono essere conservate, trasportate, raccolte e smaltite in contenitori adatti.

Queste non devono inquinare il terreno o arrivare nelle canalizzazioni!

Spiegazione dei simboli



Attenzione! Pericolo di danni materiali!

Seguono importanti indicazioni che devono essere tassativamente rispettate per evitare danni materiali!

List of components - Lista de piezas - Lista fornitori

Pos	No	No CS	Article number Número de artículo Numero articolo	List of components	Lista de piezas	Lista fornitori
-	100	10.020.07	Var	Main plate, jewelled	Platina, empedrada	Piastra con pietre
-	105/1	10.041.07	Var	Barrel bridge, jewelled	Puente de cubo, empedrado	Ponte del bariletto, con pietre
-	110	10.048.07	Var	Train wheel bridge, jewelled	Puente de rodaje, empedrado	Ponte del ruotismo con pietre
-	121/4	10.058.24	Var	Balance bridge for regulator with pointer, for shock-absorber, stud support ETACHRON, corrector	Puente de volante, para raqueta con flecha, amortiguador, porta-pitón ETACHRON y corrector	Ponte del bilanciere, per racchetta, con freccia, ammortizzatore, porta-pitone ETACHRON e corretore
-	125	10.057.07	Var	Pallet bridge, jewelled	Puente de áncora, empedrado	Ponte dell'ancora, con pietre
-	144	10.300.00	-	Dial fastener	Sujetador del cuadrante	Ferma-quadrante
-	161	80.400.00	-	Centre tube	Tubito de centro	Tubo di centro
-	180/1	20.010.00	Var	Movement barrel complete	Cubo completo de máquina	Bariletto completo del movimento
-	185	20.040.00	-	Barrel drum	Tambor de cubo	Tamburo del bariletto
-	190	20.050.00	-	Barrel cover	Tapa de cubo	Coperchio del bariletto
-	195	20.060.00	-	Barrel arbor	Árbol de cubo	Albero del bariletto
-	203	30.012.00	-	Intermediate wheel	Rueda intermedia	Ruota intermedia
-	210	30.025.00	-	Third wheel	Rueda primera	Ruota mediana
-	227	30.027.00	Var	Second wheel	Rueda de segundos	Ruota dei secondi
-	242	31.083.00	Var	Cannon pinion with driving wheel	Cañón de minutos con arrastrador	Pignone calzante con conduttore
-	255/1	31.046.06	Var	Hour wheel, assembled	Rueda de horas, montada	Ruota delle ore, montata
-	260	31.041.00	-	Minute wheel	Rueda de minutería	Ruota della minuteria
-	303/5	40.302.23	-	Two-piece regulator, with pointer, for stud support ETACHRON and corrector	Raqueta de 2 piezas, con flecha para porta-pitón ETACHRON y corrector	Racchetta in 2 pezzi, con freccia, per portapitone ETACHRON e correttore
-	358	40.380.00	Var	Regulator corrector	Corrector de raqueta	Correttore della racchetta
-	375	40.200.00	-	Stud support, ETACHRON	Porta-pitón, ETACHRON	Portapitone, ETACHRON
-	401	51.010.21	Var	Winding stem	Tija de remontuar	Albero di carica
-	407	31.121.00	-	Sliding pinion	Piñón corredizo	Pignone scorrevole
-	410	31.120.00	-	Winding pinion	Piñón de remontuar	Pignone di carica
-	415	31.020.00	-	Ratchet wheel	Rochete	Rocchetto
-	435/1	51.050.06	-	Yoke	Báscula de piñón corredizo	Bascula del pignone scorrevole
-	443/1	51.080.06	-	Setting lever	Tirete	Tiretto
-	445	51.090.00	-	Setting lever jumper	Muelle flexible de tirete	Scatto del tieritto
-	450	31.100.00	-	Setting wheel	Rueda de transmisión	Rinvio
-	453	31.101.00	-	Intermediate setting wheel	Rueda de transmisión intermedia	Rinvio intermedio
-	462	10.062.00	-	Minute train bridge	Puente de rodaje de minutería	Ponte del ruotismo di minuteria
-	705	30.040.00	Var	Escape wheel	Rueda de escape	Ruota di scappamento
-	710	40.010.00	Var	Pallet fork	Áncora	Ancora
-	721	40.050.21	Var	Timed annular balance, for shock-absorber and stud support ETACHRON	Volante anular, regulado, para amortiguador y porta-pitón ETACHRON	Bilanciere regolato, per ammortizzatore e portapitone ETACHRON
-	771	20.102.00	-	Mainspring with sliding attachment	Muelle motor con muelle de frenar	Molla-motrice con molla di freno
-	1134/1	12.030.07	Var	Automatic device framework, jewelled	Marco del dispositivo automático, empedrado	Gabbia del dispositivo automatico, con pietre
-	1141	12.051.07	Var	Automatic device lower bridge, jewelled	Puente inferior del dispositivo automático, empedrado	Ponte inferiore del dispositivo automatico, con pietre
-	1143/1	22.010.06	Var	Oscillating weight, assembled	Masa oscilante, montada	Massa oscillante, montata
-	1467	12.123.00	-	Reversing wheel maintaining plate	Placa de sujeción de rueda de inversión	Placca di guardia della ruota d'inversione
-	1471	32.105.00	-	Stop pinion	Piñón de parada	Pignone d'arresto
-	1481	32.031.00	-	Reduction wheel	Rueda de reducción	Ruota di riduzione
-	1488	32.037.00	-	Reversing wheel	Rueda de inversión	Ruota d'inversione
-	1491	52.120.00	Var	Oscillating weight bolt	Cerrojito de rueda de reducción	Paletto della massa oscillante
-	1497	22.010.00	-	Ball bearing	Rodamiento de bolillas	Cuscinetto a sfere
-	2539	53.022.00	-	Date corrector operating lever	Mando del corrector de fecha	Commando del correttore della data
-	2543	33.011.00	-	Intermediate date wheel	Rueda intermedia de fecha	Ruota intermedia del datario
-	2556	33.020.00	-	Date indicator driving wheel	Rueda de arrastre del indicador de fecha	Ruota conduttrice dell'indicatore della data
-	2557/1	91.440.22	Var	Date indicator	Indicador de fecha	Indicatore della data
-	2566	53.200.00	-	Date corrector	Corrector de fecha	Correttore della data
-	2576	53.080.00	-	Date jumper	Muelle flexible de fecha	Scatta-data
-	2595	13.111.00	-	Date jumper maintaining plate	Placa de sujeción del muelle flexible de fecha	Placca di guardia dello scatta-data

Pos	No	No CS	Article number Número de artículo Numero articolo		List of components	Lista de piezas	Lista fornitori
-	3024	70.530.00	Var		Jewelled shock-absorber for balance, bottom, to press in, shouldered	Amortiguador, empedrado, de volante, de embutir, de asiento, encima	Ammortizzatore, con pietre, del bilanciere, a pressione, con piano d'appoggio, sopra
-	3025	70.531.00	Var		Jewelled shock-absorber for balance, top, to press in, cylindrical	Amortiguador, empedrado, de volante, de embutir, cilíndrico, debajo	Ammortizzatore, con pietre, del bilanciere, a pressione, cilindrico, sotto
-	9433	56.070.00	Var		Stop lever	Palanquita-stop	Leva stop
1)	5105	10.041.01	Var	2x	Screw for barrel bridge	Tornillo del puente de cubo	Vite del ponte del bariletto
1)	5110	10.048.01	Var	2x	Screw for train wheel bridge	Tornillo de puente de rodaje	Vite del ponte del ruotismo
1)	5121	10.058.01	Var	1x	Screw for balance bridge	Tornillo del puente de volante	Vite del ponte del bilanciere
1)	5125	10.057.01	Var	1x	Screw for pallet bridge	Tornillo del puente de áncora	Vite del ponte d'ancora
2)	5445	51.090.01	Var	2x	Screw for setting lever jumper	Tornillo del muelle flexible de tirete	Vite dello scatto del tiretto
2)	5462	12.062.01	Var	1x	Screw for minute train bridge	Tornillo del puente de rodaje de minutería	Vite del ponte del ruotismo di minutería
1)	51134	12.030.01	Var	3x	Screw for automatic device framework	Tornillo del marco del dispositivo automático	Vite della gabbia del dispositivo automatico
2)	51141	12.051.01	Var	2x	Screw for automatic device lower bridge	Tornillo del puente inferior del dispositivo automático	Vite del ponte inferiore del dispositivo automatico
	51143	22.010.01	Var	3x	Screw for oscillating weight	Tornillo de masa oscilante	Vite della massa oscillante
2)	51467	12.123.01	Var	1x	Screw for reversing wheel maintaining plate	Tornillo de placa de sujeción de rueda de inversión	Vite della placca di guardia della ruota d'inversione
2)	52595	13.111.01	Var	1x	Screw for date jumper maintaining plate	Tornillo de la placa de sujeción del muelle flexible de fecha	Vite della placca di guardia dello scatto-data
					Identical screws Tornillos idénticos Viti identiche	1) 5105 5110 5124 5125 51134	2) 5445 5462 51141 51467 52595
			Var		Variante	Variante	Variant

Interchangeability and variants can be found on the ETA ONLINE SHOP (EOS):

www.eta.ch

- Customer Service
- Customer Service Portal

La intercambiabilidad y las variantes se encuentran en ETA ONLINE SHOP (EOS):

www.eta.ch











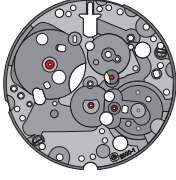
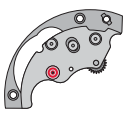





























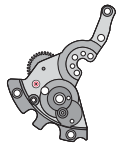

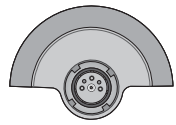



- Customer Service
- Customer Service Portal

L'intercambiabilità e le varianti si trovano sul ETA ONLINE SHOP (EOS):

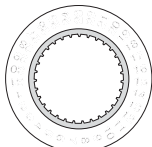
www.eta.ch

- Customer Service
- Customer Service Portal

Materials - Fornituras - Forniture

										<p>┆</p> <p>5105 5110 5121 5125 51134 Var</p>	
195											<p>┆</p> <p>5445 5462 51141 51467 52595 Var</p>
410											<p>┆</p> <p>51143 Var</p>
											
2539											

		1471
---	---	------

Order of assembly - Orden de ensamblado - Ordine di montaggio:
 Basic movement - Máquina de base - Movimento di base

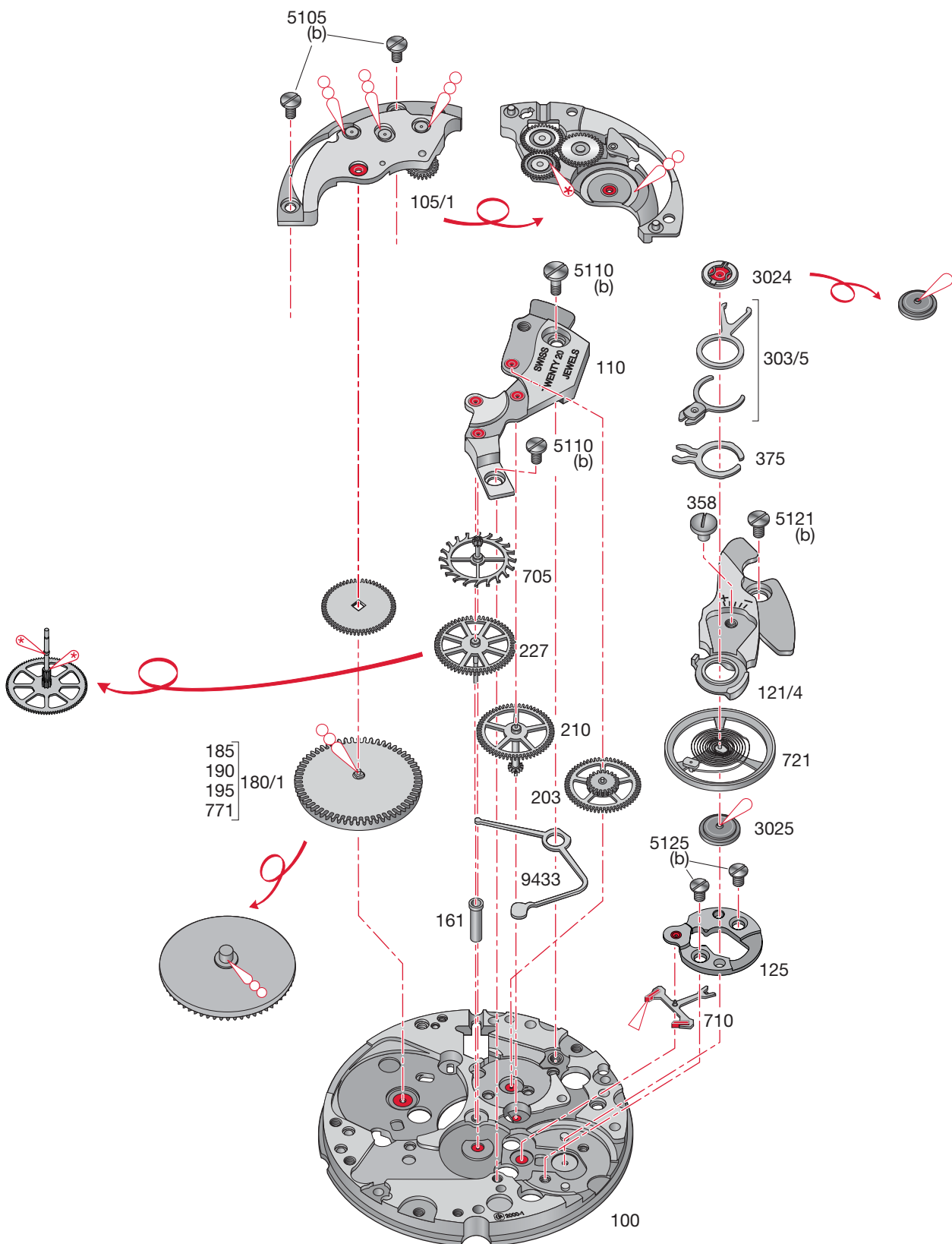

Assembling of the basic movement

(Parts listed in order of assembly)

Montaje de la máquina de base

(Lista de fornitureas por orden de ensamblado)

Montaggio del movimento di base

(Elenco delle forniture in ordine di montaggio)

100	105/1	358
161	5105 (2x)	375
3025	705	303/5
407	210	3025
410	227	3024
401	110	721
9433	5110 (2x)	121/4
203	710	5121
180/1	125	
415	5125 (2x)	

Lubrication - Lubricación - Lubrificazione

Fine oil
 Aceite fino **Moebius 9010**
 Olio fluido

Very small quantity
 Cantidad muy pequeña **Moebius 9010**
 Piccolissima quantità

Thick oil or grease
 Aceite espeso o grasa **Moebius HP-1300**
 Olio denso o grasso or / ó / o **Moebius D5**

Aceite especial para escape **Moebius 941**
 Olio speciale per scappamento or / ó / o **Moebius 9415**

M_L Minimum torque for loosening**M_L Par mínimo para desatornillar****M_L Coppia minima per svitare**

(b) 0,7 Ncm

Order of assembly - Orden de ensamblado - Ordine di montaggio:
 Self-winding mechanism - Mecanismo automático - Meccanismo automatico

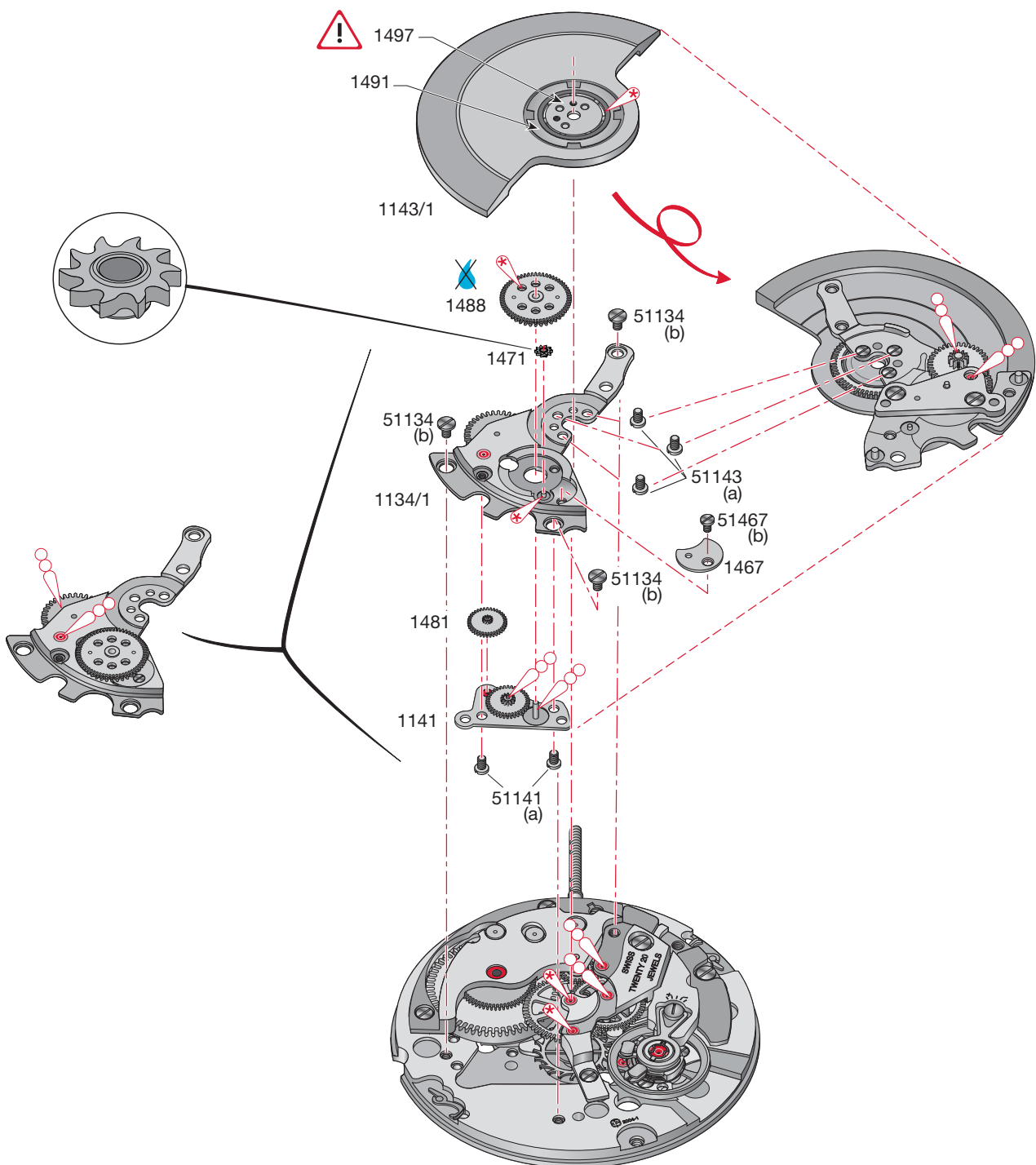

Assembling of the self-winding mechanism

(Parts listed in order of assembly)

Montaje del mecanismo automático

(Lista de fornitureas por orden de ensamblado)

Montaggio del meccanismo automatico

(Elenco delle forniture in ordine di montaggio)

1134/1	1471	1143/1
1481	1488	51143 (3x)
1141	1467	51134 (3x)
51141 (2x)	51467 (1x)	

Lubrication - Lubricación - Lubrificazione

Fine oil
 Aceite fino **Moebius 9010**
Olio fluido

Very small quantity
 Cantidad muy pequeña **Moebius 9010**
Piccolissima quantità

Thick oil or grease
 Aceite espeso o grasa **Moebius HP-1300**
Olio denso o grasso or / ó / o **Moebius D5**

Do not wash. If the part is very dirty or rusty, it should be exchanged for an original part which is lubricated and delivered by ETA SA.



Na lavar. Si la pieza está muy sucia o herrumbrosa, cambiar por una forniturea de origen entregada lubrificada por ETA SA.

Non lavare. Se il pezzo è molto sporco arrugginito, sostituire con una forniturea di origine fornita lubrificata da ETA SA.

M_L Minimum torque for loosening

M_L Par mínimo para desatornillar

M_L Coppia minima per svitare

- (a) 0,6 Ncm
- (b) 0,7 Ncm

No 1497:

Only after washing, use very little oil Moebius 9010.



Sólamente después de la limpieza por lavado, muy pequeña librificacón con Moebius 9010.

Soltanto dopo politura con lavaggio, molto debole lubrificazione con Moebius 9010.

Order of assembly - Orden de ensamblado - Ordine di montaggio:
 Hand-winding, hand-setting, date and corrector mechanisms - Cuerda manual, puesta en hora, fecha
 y corrector - Carica manuale, messa all'ora, date e correttore

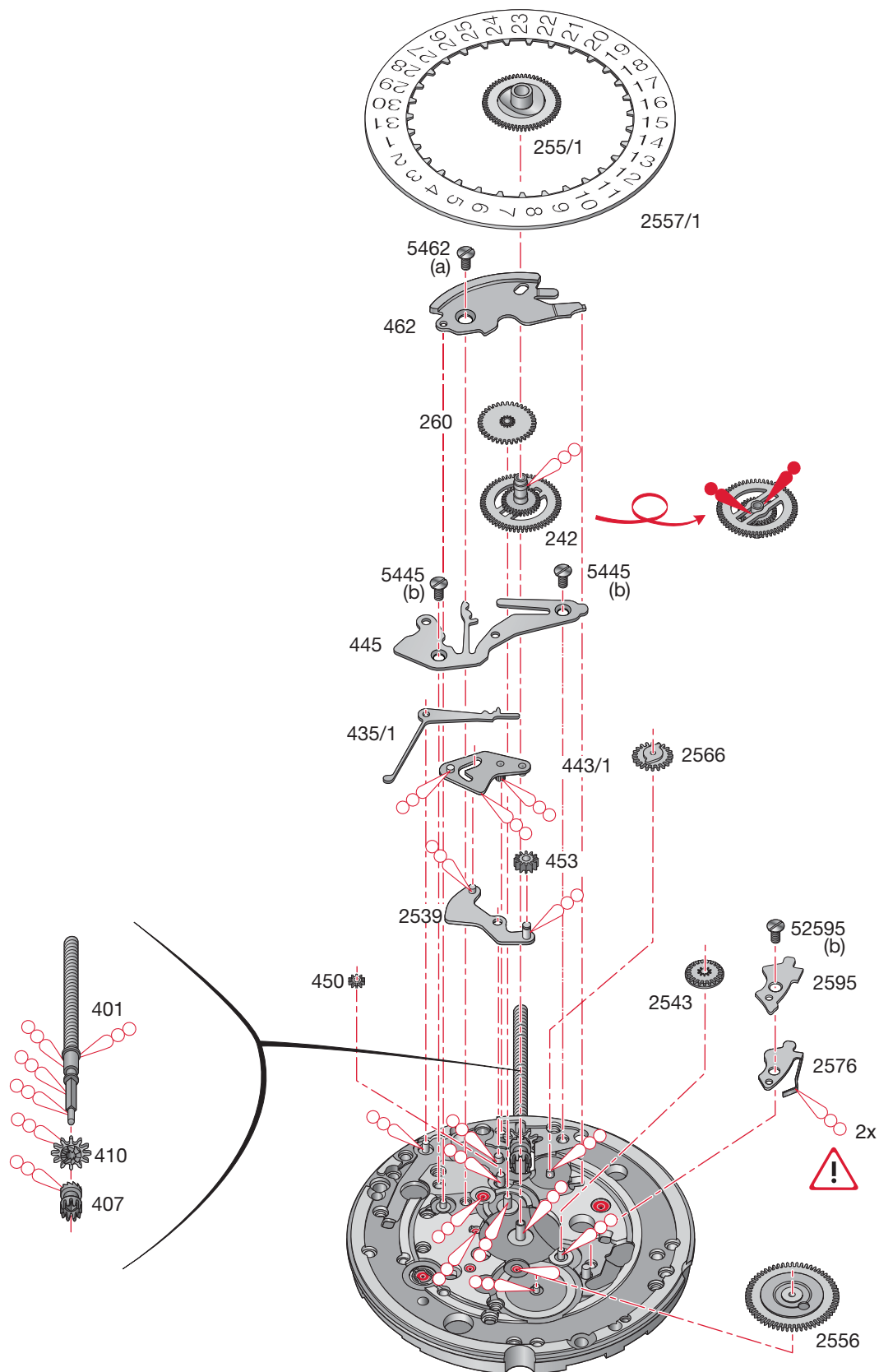

Assembling of the hand-winding, hand-setting, date and corrector mechanisms

(Parts listed in order of assembly)

Montaje del mecanismo: de cuerda manual, de puesta en hora, de fecha y de corrector

(Lista de fornitureas por orden de ensamblado)

Montaggio del meccanismo: a carica manuale, della messa all'ora, delle date e del correttore

(Elenco delle forniture in ordine di montaggio)

2539	450	2543
443/1	453	2576
435/1	2566	2595
445	462	52595 (1x)
5445 (2x)	5462 (1x)	255/1
242	2556	
260	2557/1	

Lubrication - Lubricación - Lubrificazione



Grease
Grasa
Grasso

Jismaa 124



Thick oil or grease
Aceite espeso o grasa
Olio denso o grasso

**Moebius
HP-1300
or / ó / o
Moebius D5**

M_L Minimum torque for loosening

M_L Par mínimo para desatornillar

M_L Coppia minima per svitare

- (a) 0,6 Ncm
- (b) 0,7 Ncm

	Lubricate part 2576. 1. Lubrique la pieza 2576. Lubrificare il pezzo 2576.
	Rotate part 2557/1 approx 10 teeth with rapide correction. 2. Gire la pieza 2557/1 unos 10 dientes con la corrección rápida. Ruotare il pezzo 2557/1 di circa 10 denti con la correzione rapida.
	Lubricate again part 2576. 3. Lubrique de nuevo la pieza 2576. Lubrificare di nuovo il pezzo 2576.
	Rotate part 2557/1 approx 10 teeth with rapide correction again. 4. Gire de nuevo la pieza 2557/1 unos 10 dientes con la corrección rápida. Ruotare di nuovo il pezzo 2557/1 di circa 10 denti con la correzione rapida.

We reserve all rights for this document. It is meant for the recipient only and it may not be copied, printed or given to a third person without our written permission. Quedan reservados todos los derechos relacionados con este documento, que está dirigido únicamente al destinatario. Queda por lo tanto prohibida su copia, impresión a terceros sin nuestra autorización por escrito. Ogni diritto su questo documento è riservato. Il documento è indirizzato esclusivamente al destinatario e non può essere copiato, stampato o ceduto a terzi senza un'autorizzazione scritta.

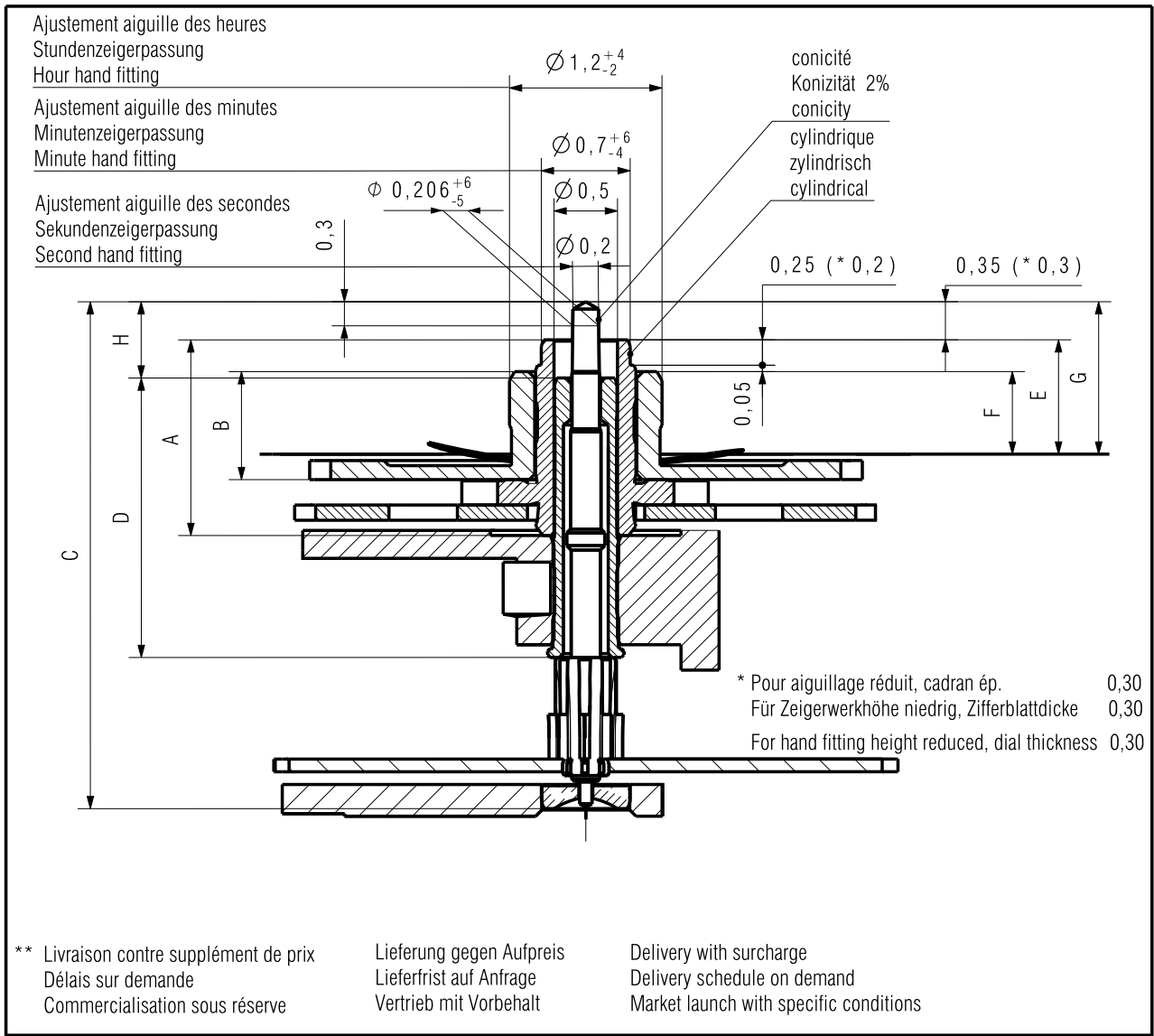

Aiguillage Zeigerwerkhöhe Hand fitting height	Longueur / Länge / Length				Dépassement Höhe über Zifferblattaufgabe Height over dial seat			H
	A	B	C	D	E	F	G	
	Chaussée Minutenrohr Cannon-pinion	Roue des heures Stundenrohr Hour wheel	Pignon des sec. Sekundentrieb Sec. wheel pin.	Tube de centre Zentrumrohr Centre tube	Chaussée Minutenrohr Cannon-pinion	Roue des heures Stundenrohr Hour wheel	Pignon des sec. Sekundentrieb Sec. wheel pin.	
réduit * niedrig reduced	1,54	0,85	3,98	2,20	0,90	0,65	1,20	0,60
1 normal	1,74	1,00	4,23	2,20	1,10	0,80	1,45	0,85
2 **	1,99	1,25	4,48	2,20	1,35	1,05	1,70	1,10
3 **	2,24	1,50	4,73	2,20	1,60	1,30	1,95	1,35

Kaliber / Calibre / Caliber	Masstab Echelle Scale		CATIA V5
2000-1	--	Masse in mm Dimensions en mm Dimensions in mm	Tol.1/1000 mm
2004-1			

AIGUILLAGES ZEIGERWERKHÖHEN HAND FITTING HEIGHTS	Version	Revision	Blatt Feuille Sheet
Z0091638	02	00	01/01

 ETA SA MANUFACTURE HORLOGÈRE SUISSE DEPUIS 1793 A COMPANY OF THE SWATCH GROUP	Ersatz für/En remplacement de/Remplacement for	Klass.	ZVACC	KUN
	Aenderung/Modification	Erstellt Etabli Created	Geprüft Contrôlé Controlled	Freigegeben Libéré Released
	23986	17.09.2008 LID	22.09.2008 HID	23.09.2008 FEU

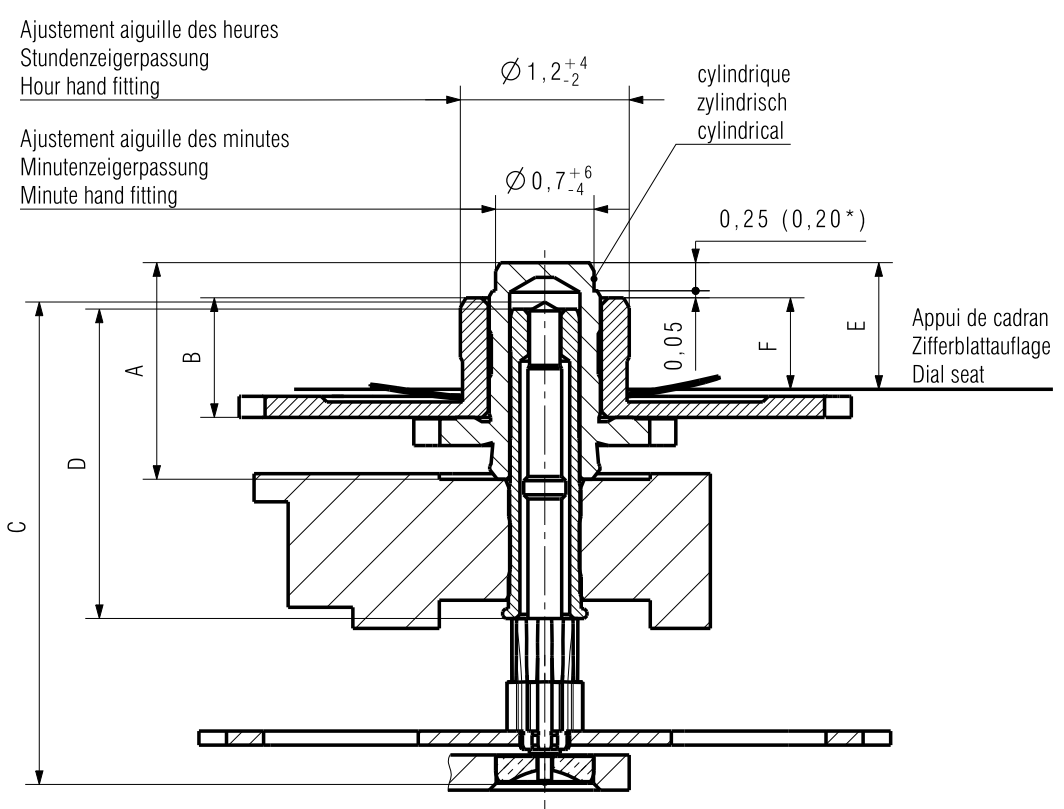

* Pour aiguillage réduit, cadran ép. 0,30
 Für Zeigerwerkhöhe niedrig, Zifferblattdicke 0,30
 For Hand fitting height reduced, dial thickness 0,30

Aiguillage Zeigerwerkhöhe Hand fitting height	Longueur / Länge / Length				Dépassement Höhe über Zifferblattauflage Height over dial seat	
	A	B	C	D	E	F
réduit * niedrig reduced	1,54	0,85	3,43	2,20	0,90	0,65
1	1,74	1,00	3,43	2,20	1,10	0,80
2	1,99	1,25	3,43	2,20	1,35	1,05
3	2,24	1,50	3,43	2,20	1,60	1,30

Kaliber / Calibre / Caliber 2000-1 2004-1	Masstab Echelle Scale --		CATIA V5 Masse in mm Dimensions en mm Dimensions in mm Tol.1/1000 mm
---	-----------------------------------	--	--

AIGUILLAGES ZEIGERWERKHÖHEN HAND FITTING HEIGHTS	sans seconde ohne Sekunde without second	Version 02	Revision Révision 00	Blatt Feuille Sheet 01/01
--	--	---------------	----------------------------	------------------------------------

 ETA SA MANUFACTURE HORLOGÈRE SUISSE DEPUIS 1793 A COMPANY OF THE SWATCH GROUP	Ersatz für/En remplacement de/Remplacement for Aenderung/Modification 23986	Klass. Class. ZVACC	KUN
	Erstellt Etabli Created 17.09.2008	Geprüft Contrôlé Controlled LID	Freigegeben Libéré Released 23.09.2008

We reserve all rights for this document. It is meant for the recipient only and it may not be copied, printed or given to a third person without our written permission. Quedan reservados todos los derechos relacionados con este documento, que está dirigido únicamente al destinatario. Queda por lo tanto prohibida su copia, impresión a terceros sin nuestra autorización por escrito. Ogni diritto su questo documento è riservato. Il documento è indirizzato esclusivamente al destinatario e non può essere copiato, stampato o ceduto a terzi senza un'autorizzazione scritta.

This page has deliberately been left blank in case of A3 format printing.

Esta página se han dejado en blanco a propósito en caso de imprimirla en formato A3.

Questa pagina è lasciata intenzionalmente bianca in caso di stampa formato A3.

This page has deliberately been left blank in case of A3 format printing.

Esta página se han dejado en blanco a propósito en caso de imprimirla en formato A3.

Questa pagina è lasciata intenzionalmente bianca in caso di stampa formato A3.

Modifications compared with previous document versions**Modificaciones comparadas con las versiones anteriores del documento****Modifiche comparate con le versioni precedenti del documento**

Version Versión Versione	Date Fecha Data	Modification	Modificación	Modifica	Page Página Pagina
09.1	25.10.2011	Frequency	Frecuencia	Frequenza	1
09	08.07.2011	Assembling (part No 161)	Montaje (pieza No. 161)	Montaggio (pezzo No 161)	6
		Assembling	Montaje	Montaggio	8,10
08	15.06.2010	Assembling	Montaje	Montaggio	8,10
		Assembling	Montaje	Montaggio	6-10
07	06.05.2010	Materials (Variant)	Fornituras (Variante)	Forniture (Variante)	5
		List of components (Variant)	Lista de piezas (Variante)	Lista fornitori (Variante)	2-3
06	06.01.2009	Remove parts No 714 and 5102 from materials chapter	Eliminar piezas No 714 y 5102 del capítulo "fornituras"	Soppressione degli pezzi No 714 e 5102 nel capitolo delle forniture	2-3
		Addition parts No 1491 and 1497	Piezas No 1491 y 1497 adicional	Agungere degli pezzi No 1491 e 1497	4
		Remove part No 5102	Eliminar pieza No 5102	Soppressione del pezzo No 5102	4
		Correction of lubrication (part No 242)	Corrección de la lubricación (pieza No 242)	Correzione di lubrificazione (pezzo No 242)	7
05	14.11.2008	New drawings	Nuevos planos	Diseigni nuovi	8-9
		New layout	Nuevo layout	Nuova layout	1-12
04	19.05.2008	Part 2576: Lubrication	Pieza 2576: Lubricación	Part 2576: Lubrication	7
		Minimum torque for loosening	Par mínimo para desatornillar	Coppia minima per svitare	3, 5-7
		Part 5445: No CS	Pieza 5445: No CS	Pezzo 5445: No CS	3
03	14.12.2004	New logos	Nueva logos	Nuevi logos	1, 12
		Basic version	Versión de base	Versione di base	--

All modifications reserved.

Salvo modificación.

Con riserva di ogni eventuale modifica.

This document can be found on the Customer Service Portal (CSP):**www.eta.ch**

- Customer Service
- Customer Service Portal
- Technical Documents

Este documento se encuentran en el Customer Service Portal (CSP):**www.eta.ch**

- Customer Service
- Customer Service Portal
- Technical Documents

Il presente documento si trovano sul Customer Service Portal (CSP):**www.eta.ch**

- Customer Service
- Customer Service Portal
- Technical Documents



ETA^{SA}
MANUFACTURE HORLOGÈRE SUISSE
DEPUIS 1793

CUSTOMER SERVICE

Bahnhofstrasse 9
P.O. Box 359
2540 Grenchen
Switzerland

Phone +41 (0)32 655 27 77
Fax +41 (0)32 655 84 30

etacs@eta.ch
www.eta.ch